

23H056.4.8

TECHLF

3 Grand Rue

11400 Villeneuve La Comptal

France

SIRET : 453 137 283 00017 - APE : 742C

TVA : FR26 453 137 283

Tél : 04 68 23 22 01

E-mail: techlf@techlf.com

www.techlf.com



Actually the best choice, capable of optimizing a wide variety of industrial stepper motor control applications.

Typical applications :

- ▶ 3 or 4 axis milling machine
- ▶ lathe
- ▶ linear motion
- ▶ robot
- ▶ etc...

.Wiring Diagram

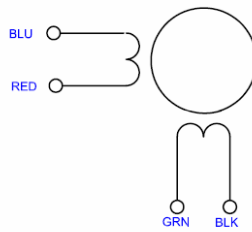

.Wiring Diagram

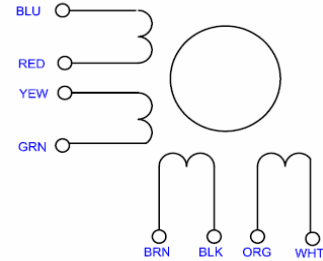

.Dimensions:

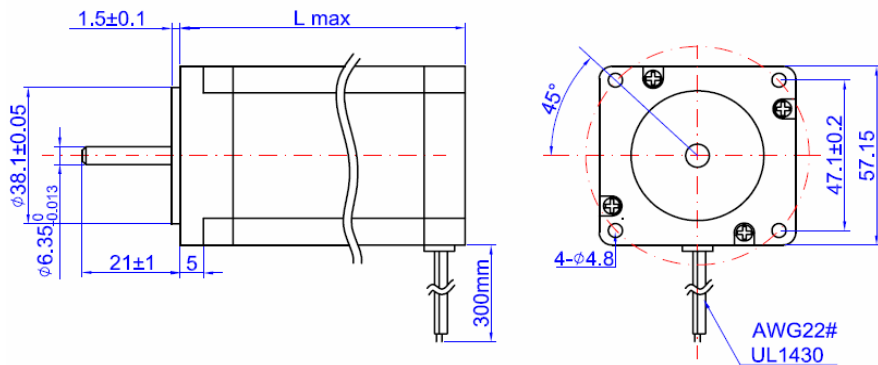

Model Number	Step Angle Degree	Motor Length L mm	Holding Torque Nm	Number Of leads Number	Current Phase Amp	Resistance Phase ohm	Inductance Phase mH	Rotor Inertia g.cm ²	Detent Torque g.cm	Weight kg
23H056-4	1.8	55	1.0	4	2.1	1.6	3.1	210	520	0.6
23H056-8	1.8	55	1.0	8	2.1	1.6	3.1	210	520	0.6

TECHLF